



CEA30006

Hand Crank Series CEA

- Designed to increase safety in the work area with a resulting increase in efficiency and productivity
- Welding cable reels store work lead or electrode lead, up to #2/0, safely and effectively when not in use. Each lead requires a separate reel. When welding also refer to ANSI/Asc Z 49.1

- Cable reels have a current path through a continuous 400 AMP, 90VDC (maximum) rated enclosed slip ring
- Stores cable when not in use eliminating tangled, kinked welding cables
- Maintains proper bend radius of cables - providing longer cable life
- Keeps work area and vehicles better organized resulting in better space utilization



WC80000

Shown with electrode, clamp and cable (not included)

WC7000

Spring Driven Series WC

Made in USA

FEATURES

- ✓ All bolted heavy gauge steel construction provides long life and ease of use and maintenance.
- ✓ Manual drum lock prevents spool from turning when not in use preventing unwanted pay out of cable.

APPLICATIONS

- Steel Mills and Foundries
- Metal Working and fabrication
- Auto / Truck Service
- Power Generation and transmission
- Agricultural
- Railroads
- Mining (above ground)

Caution:

If cable reels are to be used for extended periods of time, unwind all cable from reel to prevent heat build-up. For indoor non weather-tight applications only.

SPECIFICATIONS All reels sold without cable

MODEL	REEL CAPACITY				WEIGHT				
	#2 (31mm ²)		#1 (39mm ²)				#1/0 (50mm ²)		#2/0 (62mm ²)
CABLE SIZE	ft / m		ft / m		ft / m		ft / m		lbs / kg
CEA30006	300	91	250	76	200	61	150	46	49 22
CEA30012	500*	152	500*	152	400	122	300	91	56 25
WC7000	_____		50	15	50	15	50	15	49 22
WC80001	_____		75	22	75	22	75	22	80 36
WC80002	_____		100	31	_____	_____	_____	_____	81 37

*May exceed maximum cable length allowable for most welding applications
NOTE: Each cable requires separate reel.

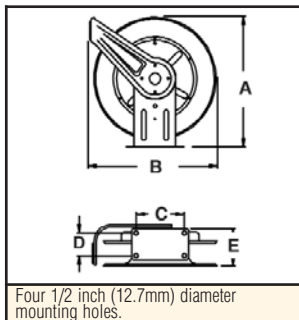

WC DIMENSIONS		WC7000		WC80000	
		in / mm		in / mm	
A	20 1/4	512	25 3/8	645	
B	19	483	24	610	
C	7 7/8	200	10	254	
D	3 7/8	98	6	152	
E	14 3/4	362	16	406	

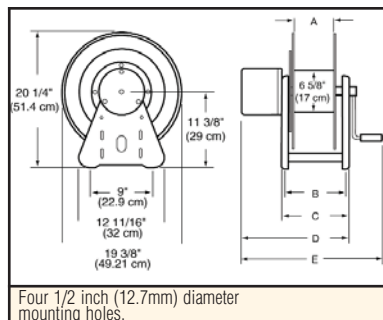

CEA DIMENSIONS		CEA30006		CEA30012	
		in / mm		in / mm	
A	6	152	12	305	
B	9.75	248	15.75	400	
C	11	279	17	432	
D	15	381	21	533	
E	21	533	27	686	

North America: 800-444-3134
Europe: +44 (0) 1536 406999

Asia: +63 (45) 625-6624
Latin America: 260-489-1685

Reelcraft Industries is
ISO 9001:2000
Certified Since 1996

Models listed with an icon can be shipped same day upon request when the order is received by 11:30 AM local time for quantities of 5 or fewer.



Indiana Warehouse



California Warehouse



Indiana & California
Warehouses



Canadian Warehouse